

Pro.2

**100m USB3.2 Gen1 Extender over single
Cat5e/6 Cable**

Model: USB32CAT14C

/// OPERATION MANUAL



Dear Customer

Thank you for purchasing this product. For optimum performance and safety, please read these instructions carefully before connecting, operating or adjusting this product. Please keep this manual for future reference.

FEATURES

- USB 3.2 Gen1 up to 5Gbps
- Transmission distance up to 100m(328ft) with Cat6 cable
- 1x USB Type-C on Host
- 3x USB-A and 1x USB Type-C on device
- Compatible with USB 2.0/1.1
- Support RS232 transmission
- Support POC(TX powered by RX)

NOTICE

Our company reserves the right to make changes in the hardware, packaging and any accompanying documentation without prior written notice.

TABLE OF CONTENTS

Specifications
Package Contents
Panel Descriptions
Connecting and Operating
Typical Application
Maintenance
Product Service
Warranty



- 1 This product is warranted for 12 months from the date of purchase.**
Subject to the conditions of this warranty, the Customer Care Centre will perform necessary service on the product without charge for parts, or labour if, in the opinion of the manufacturer/ manufacturer's agent, the product is found to be faulty within the warranty period.
- 2** This warranty only applies if the product has been installed and used in accordance with the manufacturer's recommendations (as noted in the operating instructions) under normal use and reasonable care. The warranty covers normal domestic use only and does not cover damage, malfunction or failure resulting from use of incorrect voltage, accident, misuse, neglect, build-up of dirt or dust, abuse, mis-adjustment of customer controls, mains supply problems, thunderstorm activity, infestation by insects or vermin, tampering or repair by unauthorised persons (including unauthorised alterations), exposure to abnormally corrosive conditions or any foreign object or matter having entered the product.
- 3** If warranty service is required you should:
 - Telephone the Customer Care Centre on 1300 662 946
 - Provide a copy of your purchase receipt that shows retailer's identity and date of purchase.
 - Send or bring the product to your Customer Care Centre.
Please note that freight to and/or from your Customer Care Centre must be arranged by you.
- 4** The warranties hereby conferred do not extend to any costs associated with the delivery, handling, freighting or transportation of the product or any part thereof or replacement of and do not extend to any damage or loss occurring during, or associated with transit.

**THIS WARRANTY CARD AND THE PURCHASE DOCKET
(OR SIMILAR PROOF OF PURCHASE)
SHOULD BE RETAINED BY THE CUSTOMER AT ALL TIMES**

**TROUBLE SHOOTING HELP LINE
(03) 9321 8300**

Customer Care Centre
562 Spencer Street, West Melbourne
VICTORIA 3003

Pro.2
Providing AV Solutions

This advice does not limit, override or later your guaranteed rights under the Australian Consumer Law, including remedies for any failure of the Consumer Guarantees, which may include repair or replacement or it a Major Failure (as defined under the Australian Consumer Law) a replacement or refund. These guaranteed rights cannot be varied by Pro.2 or retailers of its products and have no set time limit.

MAINTENANCE

Clean this unit with a soft, dry cloth. Never use alcohol, paint thinner or benzene to clean this unit.

PRODUCT SERVICE**1) Damage requiring service:**

The unit should be serviced by qualified service personnel if:

- (a) The DC power supply cord or AC adaptor has been damaged;
- (b) Objects or liquids have gotten into the unit;
- (c) The unit has been exposed to rain;
- (d) The unit does not operate normally or exhibits a marked change in performance;
- (e) The unit has been dropped or the cabinet damaged.

2) Servicing Personnel: Do not attempt to service the unit beyond that described in these operating instructions. Refer all other servicing to authorized servicing personnel.

3) Replacement parts: When parts need replacing ensure the servicer uses parts specified by the manufacturer or parts that have the same characteristics as the original parts. Unauthorized substitutes may result in fire, electric shock, or other hazards.

4) Safety check: After repairs or service, ask the servicer to perform safety checks to confirm that the unit is in proper working condition.

SPECIFICATIONS

Operating Temperature Range	0 to +40°C(+32 to +104°F)
Operating Humidity Range	5 to 90%RH (No Condensation)
USB port at HOST	1x USB Type C
USB port at Device	3x USB3.0 Type A, 1x USB Type C
Support operating systems	MAC OS v8.6 and above version,windows7/8/10, Linux system
Transmission speed	5Gbps
Data transmission Distance	100m over CAT5e/CAT6 cable
Dimension (L×W×H)	Host:104.24x80.51x24.1mm, Device: 102.55x91.2x24.1mm
Power supply	DC12V/3A

Note1: Specifications are subject to change without notice. Mass and dimensions are approximate.

PACKING CONTENTS

- 1) Main Unit. USB Extender
- 2) Operating Instructions
- 3) Power adapter DC12V/3A x1 PCS

PANEL DESCRIPTIONS

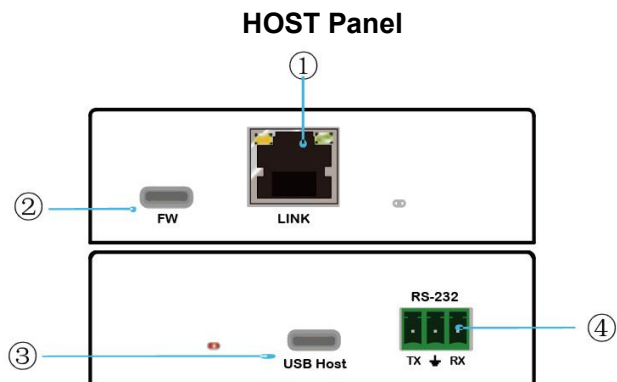

- 1) Cat5e/6 output port.
- 2) Firmware update
- 3) USB Host Input
- 4) RS232 port

Device Panel

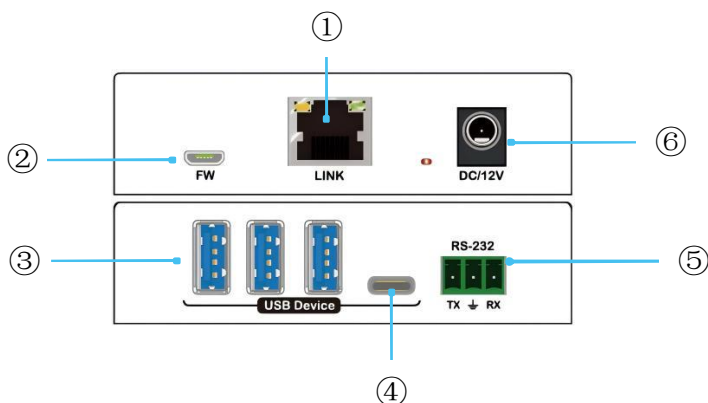

- 1) Cat5e/6 input port.
- 2) Firmware update
- 3) USB Device Type A x 3
- 4) USB Device Type C
- 5) RS232 Port
- 6) Power Input

CONNECTING AND OPERATING

- 1) Connect the data input source (such as PC host etc) into transmitter over USB cable.
- 2) Connect the output of transmitter and input of receiver over CAT5E or CAT6 cable.
- 3) Connect the data output (such as scanner/mouse/keyboard/printer/Mobile HDD etc.) into the receiver over USB cable.
- 4) Connect power adapter into the receiver.

NOTE: Insert/Extract cables gently.

Typical Application

